



# union iron

## TEMP-STOR CONTAINMENT WALL SYSTEM

ALL MODELS  
ASSEMBLY & OPERATION



Read this manual before using product. Failure to follow instructions and safety precautions can result in serious injury, death, or property damage. Keep manual for future reference.

Part Number: ITSM0308-R1

Revised: Mar/10



# TABLE OF CONTENTS

- 1. Introduction ..... 5**
- 2. Safety First..... 7**
  - 2.1. General Safety ..... 8
  - 2.2. Installation Safety ..... 9
- 3. Assembly ..... 11**
  - 3.1. Placement ..... 11
  - 3.2. Wall Panel Assembly..... 12
  - 3.3. Containment Wall System Assembly ..... 14
  - 3.4. Aeration System Installation..... 15
  - 3.5. Portable Filling Procedure ..... 15
- 4. Appendix..... 17**
  - 4.1. Integra Tarp Instructions - Oval..... 17
- Limited Warranty ..... 21



# 1. Introduction

Congratulations on your purchase of a Union Iron Temp-Stor Containment Wall System.

Temp-Stor temporary grain storage systems are engineered for long life, with galvanized c-channel construction and support angles fabricated from 7.6 cm x 7.6 cm galvanized angle. They are portable and can be easily moved from one location to another or reconfigured as individual storage needs change. The 3 m wall panel modules are pre-assembled—the legs just need to be unfolded and bolted in position. The modular design allows the system to be installed on slightly uneven surfaces, requiring minimal site preparation.

Before using the Temp-Stor, give this manual to the people who will be operating and maintaining the equipment. Reading and understanding the manual will reduce downtime and equipment failure, as well as ensure safe and efficient operation. A sign-off form is provided on the inside front cover for your convenience.

Customer:	
Type of Equipment:	
Order Number:	
Serial Number:	



## 2. Safety First



The Safety Alert symbol to the left identifies important safety messages on the product and in the manual. When you see this symbol, be alert to the possibility of personal injury or death. Follow the instructions in the safety messages. Why is SAFETY important to you?

Three big reasons:

- Accidents disable and kill.
- Accidents cost.
- Accidents can be avoided.

### SIGNAL WORDS

Note the use of the signal words **DANGER**, **WARNING**, **CAUTION**, and **NOTICE** with the safety messages. The appropriate signal word for each message has been selected using the definitions below as a guideline.

The Safety Alert symbol means ATTENTION, BE ALERT!, YOUR SAFETY IS INVOLVED.

<b>DANGER</b>	
	Indicates an imminently hazardous situation that, if not avoided, will result in serious injury or death.

<b>WARNING</b>	
	Indicates a hazardous situation that, if not avoided, could result in serious injury or death.

<b>CAUTION</b>	
	Indicates a hazardous situation that, if not avoided, may result in minor or moderate injury.

<b>NOTICE</b>	
	Indicates a potentially hazardous situation that, if not avoided, may result in property damage.

## 2.1. GENERAL SAFETY

**Important:** *The general safety section includes instructions that apply to all safety practices. Any instructions specific to a certain safety practice (e.g., assembly safety), can be found in the appropriate section. Always read the complete instructional sections and not just these safety summaries before doing anything with the equipment.*

**YOU** are responsible for the **SAFE** use and maintenance of your equipment. **YOU** must ensure that you and anyone else who is going to work around the equipment understands all procedures and related **SAFETY** information contained in this manual.

Remember, **YOU** are the key to safety. Good safety practices not only protect you, but also the people around you. Make these practices a working part of your safety program.

- It is the equipment owner and the operator's responsibility to read and understand **ALL** safety instructions, safety decals, and manuals and follow them before assembling, operating, or maintaining the equipment. All accidents can be avoided.
- Equipment owners must give instructions and review the information initially and annually with all personnel before allowing them to operate this product. Untrained users/operators expose themselves and bystanders to possible serious injury or death.
- Use this equipment for its intended purposes only.
- Do not modify the equipment in any way. Unauthorized modification may impair the function and/or safety, and could affect the life of the equipment. Any modification to the equipment voids the warranty.
- Do not allow children, spectators, or bystanders within the work area.
- Have a first-aid kit available for use should the need arise, and know how to use it.
- Provide a fire extinguisher for use in case of an accident. Store in a highly visible place.
- Wear appropriate protective gear. This list includes, but is not limited to:
  - a hard hat
  - gloves
  - protective shoes with slip-resistant soles
  - protective goggles
  - hearing protection
- For Powered Equipment: before servicing, adjusting, or repairing powered equipment, unplug, place all controls in neutral or off position, stop the engine or motor, remove ignition key or lock out power source, and wait for all moving parts to stop.



- Follow good shop practices:
  - keep service area clean and dry
  - be sure electrical outlets and tools are properly grounded
  - use adequate light for the job at hand
  - Think SAFETY! Work SAFELY!



## 2.2. INSTALLATION SAFETY

---

- Check all equipment for damage immediately upon arrival. Do not attempt to install a damaged item.
- Have 2 people handle the heavy, bulky components.



# 3. Assembly

**Warning:** Before continuing, please reread the safety information relevant to this section at the beginning of this manual. Failure to follow the safety instructions can result in serious injury, death, or property damage.

## 3.1. PLACEMENT

The area of construction should be stripped of all vegetation and proof rolled with a large vibratory compactor. Compact any fill necessary to bring the ground surface to grade to a minimum of 98% of the maximum dry density obtained from the standard Proctor compaction test.

- Crown: A minimum of 1.25 cm per 3 m fall to the outside is recommended to allow for drainage away from the storage area. The area of compaction should extend approximately 3 m beyond the end of the base angle.

**Note:** Information is provided only as a guideline. Consult your soils engineer for formal site-specific recommendations.

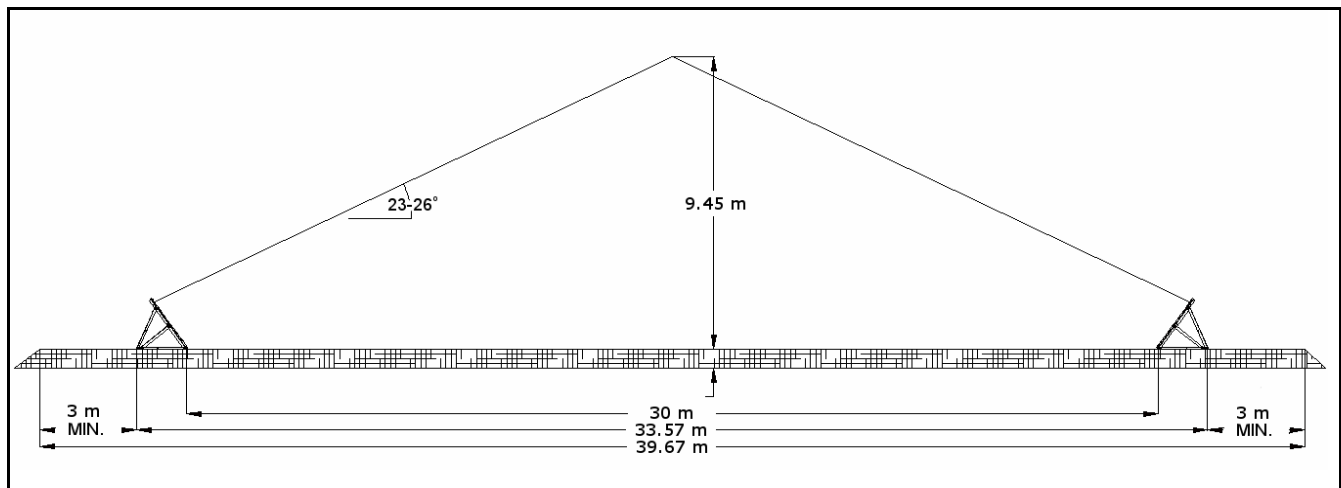

**Figure 3.1 Wall Panel Arrangement**

**Important:** The capacity of the Temp-Stor Containment Wall System is based on containment walls being filled with grain to the top of the upper steel wall panel using a 23° average angle of repose (the angle at which the surface of a freely formed pile of grain makes to the horizontal). The actual angle of repose will vary depending on grain moisture content, foreign material, piling method, and type of grain. It is the responsibility of the customer to advise Union Iron Works if actual conditions will vary from the above design parameters.

**NOTICE**

Failure to properly prepare the site could result in shifting of the wall modules and loss of grain from the Temp-Stor system.

## 3.2. WALL PANEL ASSEMBLY

Temp-Stor Containment wall panels are shipped collapsed with the support angles folded underneath and bolted together for shipment.

1. To erect the wall panel, remove the 1.6 cm x 5 cm large shipping bolts connecting the center holes in the wall support angles, lower base angles, and upper support brace angles. See Figure 3.2.

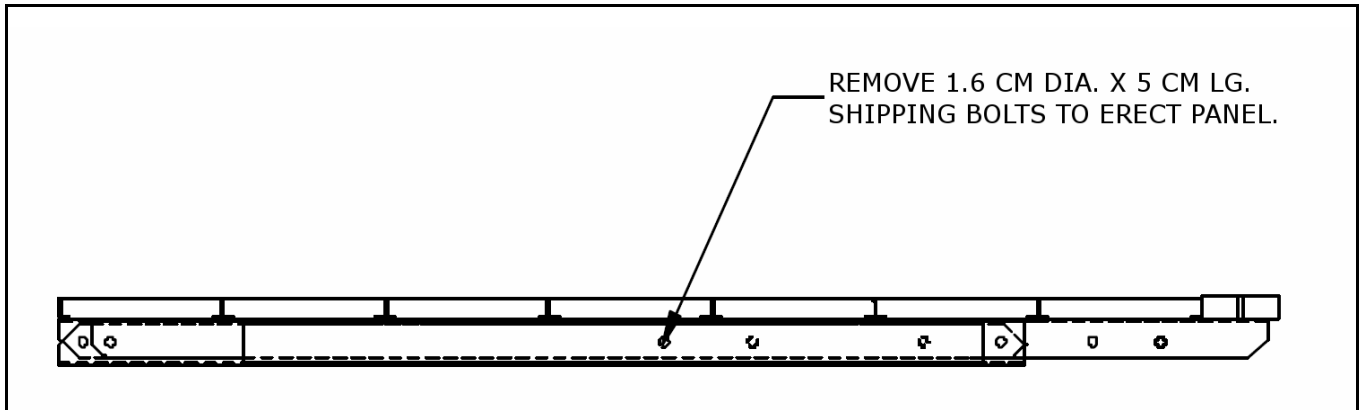
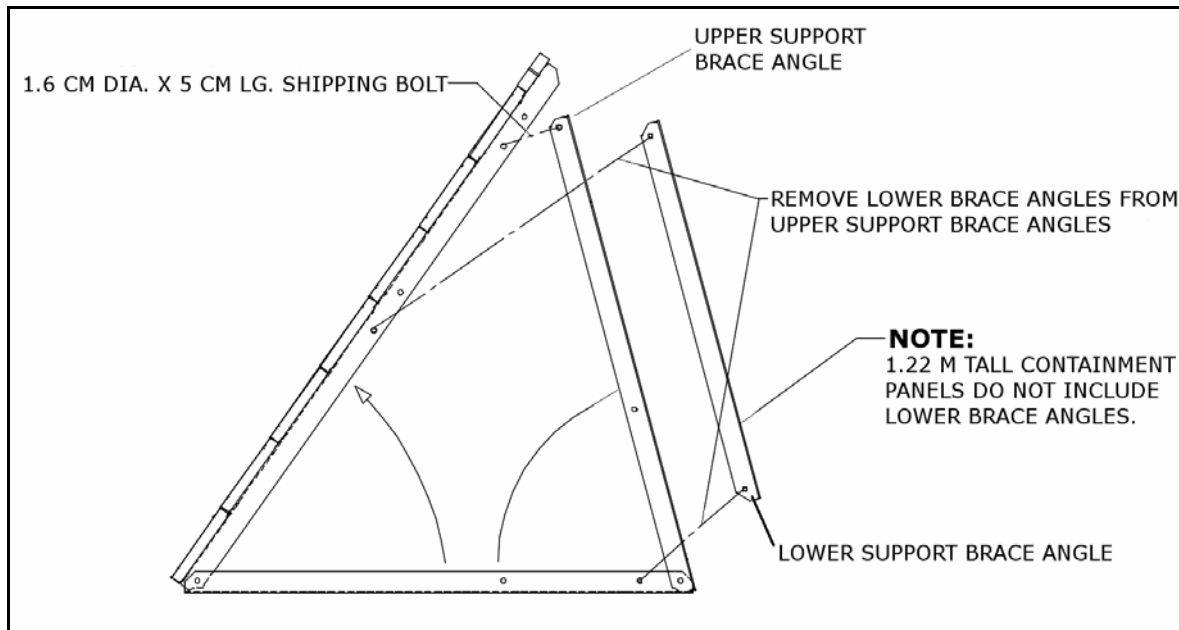

Figure 3.2 Folded Containment Panel

2. Swing the containment panel upward. Swing the upper support brace angles upward.
3. Connect the upper support brace angles to the wall support angle with the 1.6 cm x 5 cm large shipping bolt by inserting it in the second hole from the top of the upper support angle as shown in Figure 3.3.

**NOTICE**

Do not lift the containment panel by the top header board as this may damage the board.



**Figure 3.3 Partially Assembled Containment Panel**

4. Remove the two 1.6 cm x 3.8 cm large bolts connecting each lower support brace angle to the upper support brace angle. Using the 1.6 cm x 3.8 cm bolts, connect the lower support brace angles to the wall support angles and lower base angles in the holes as shown in Figure 3.4.

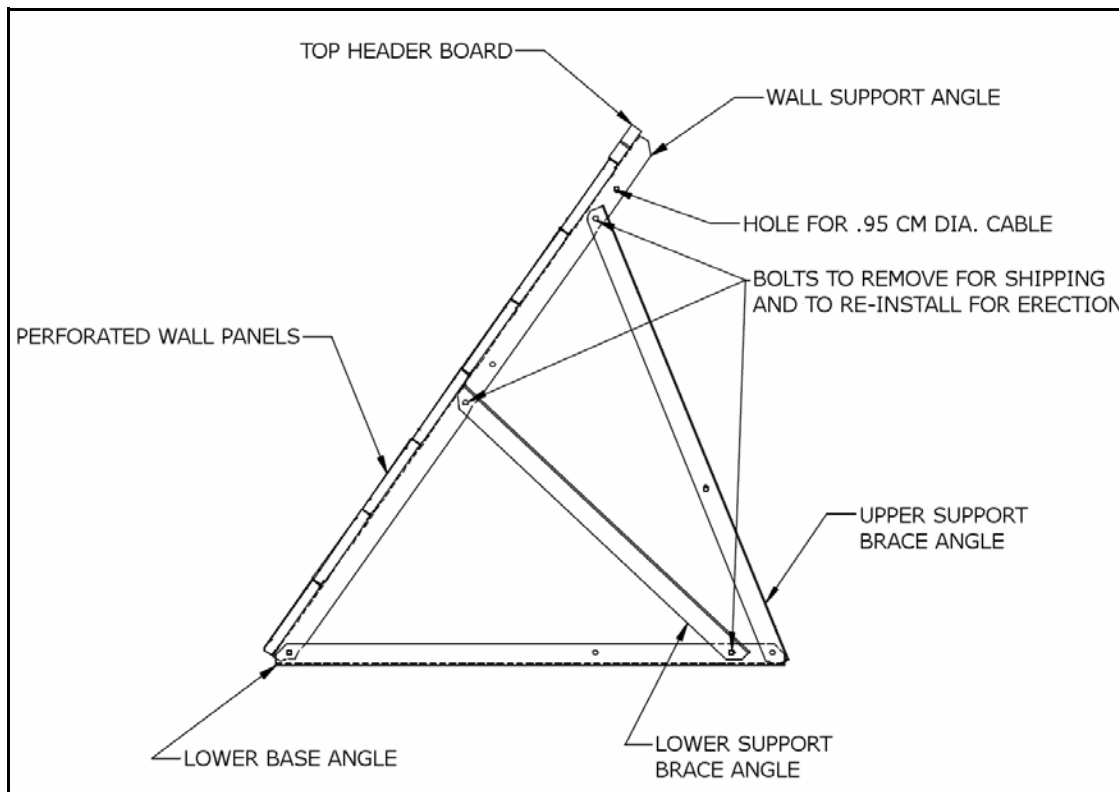
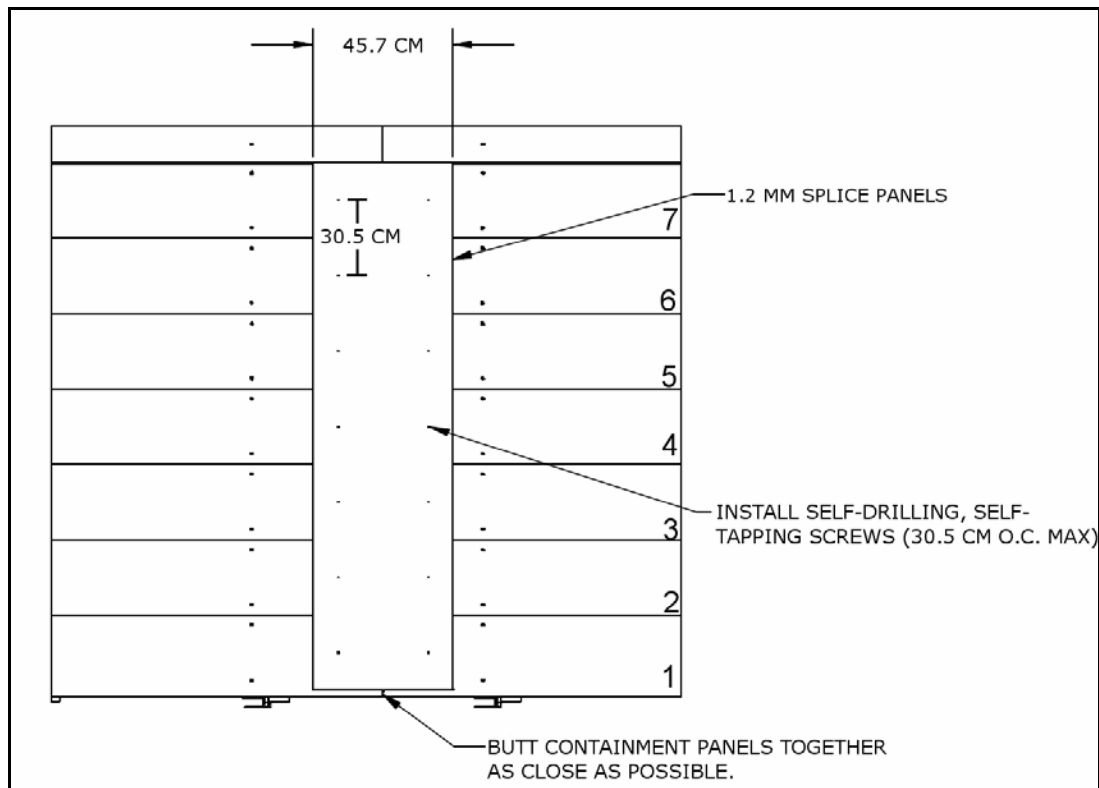

**Figure 3.4 Fully Assembled Containment Panel**

5. Securely tighten all bolts.
6. Repeat until all wall panels are assembled.

### 3.3. CONTAINMENT WALL SYSTEM ASSEMBLY

1. Set all containment wall panels in place on the pad. Butt the wall panels together as close as possible. See Figure 3.5.

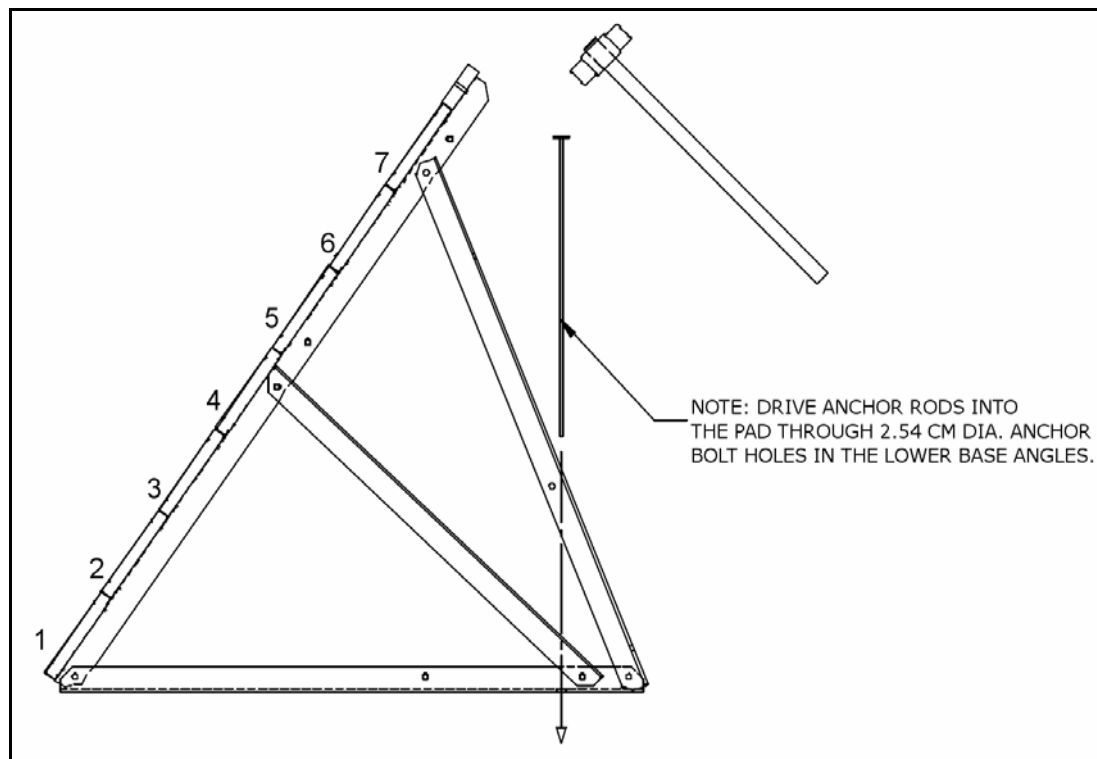

**Figure 3.5 Splice Panel**

2. Using a large hammer, drive the anchor rods through the 2.54 cm holes in the lower base angles as shown in Figure 3.6.

**Note:** *The 1.22 m and 1.83 m Temp-Stor Containment Wall Systems require 91.4 cm anchor rods, while 2.74 m systems require two 1.22 m anchor rods per lower base angle. See Figure 3.6.*

3. Center 45.7 cm wide x 1.2 mm splice panels over joints between containment wall panels, and attach to wall panels with 1.11 cm x 2.54 cm large self-drilling, self-tapping screws, 30.5 cm apart (maximum). See Figure 3.5.
4. Thread the .95 cm cable through the upper holes of the wall support angles as shown in Figure 3.4. Tension the cable as required using the cable clamps and turnbuckles. Panels may be removed for filling and emptying by securely attaching the cable to the wall panels on either side of the opening, and tensioning as outlined above.



**Figure 3.6 Anchor Rods**

5. When the panels removed are reset, thread a shorter cable through the upper holes of the wall support angles on these wall panels and attach to the wall panels on either side of the opening, tensioning as required.

**Note:** *The 2.74 m Temp-Stor Containment Wall Systems require two cables, one at the top of the wall panels and one at the midpoint of the wall panels. See Figure 3.4.*  
*For removing panels, Tek Screws on splice panel should be installed from outside for accessibility.*

## 3.4. AERATION SYSTEM INSTALLATION

Install the aeration piping system as shown in the assembly drawing for your equipment. Holes for the aeration piping may be cut in the wall panels using either a torch or a reciprocating saw.

## 3.5. PORTABLE FILLING PROCEDURE

1. Positioning an auger or belt conveyor on one end of the Temp-Stor Containment Wall System, begin filling the unit until the grain has reached the top of the containment walls, forming a pile with an approximate 23° angle of repose.
2. Continue filling until entire Temp-Stor Containment Wall System is at full capacity.



# 4. Appendix

## 4.1. INTEGRA TARP INSTRUCTIONS - OVAL

1. Place a pipe through the core of the roll. Hang chains from a forklift down to each end of the pipe. Remove wrapping, being careful not to cut grain cover. Position the roll about two-thirds of the way back the length of the bunker with the open edge white side facing up, directed towards two-thirds of the pile. See Figure 4.1.

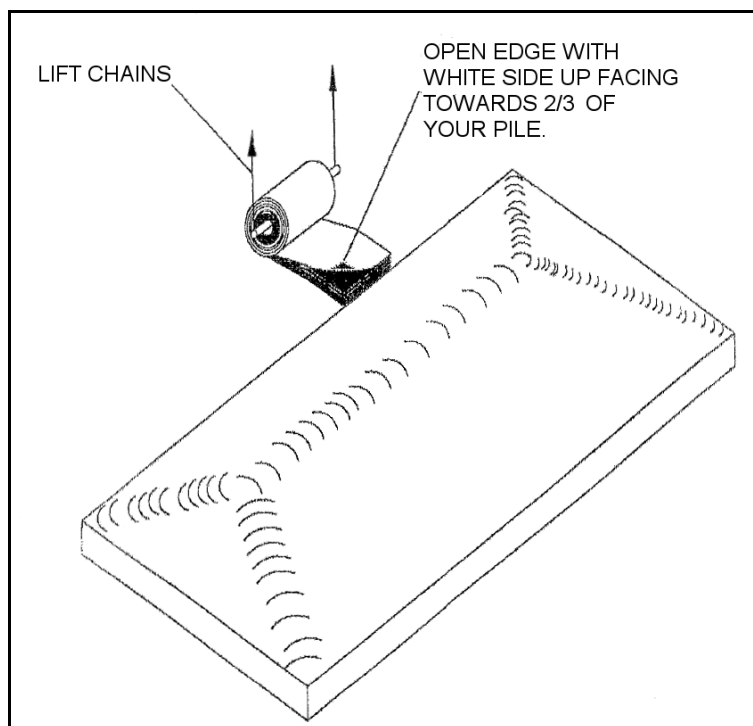

**Figure 4.1**

2. Attach a rope to the end layers of the roll. Place about 3 old tires at the peak of the pile. Run the rope through them over to the other side and tie to a pulling vehicle. Use another rope tied to the tires at the peak and anchor it near the roll. See Figure 4.2.

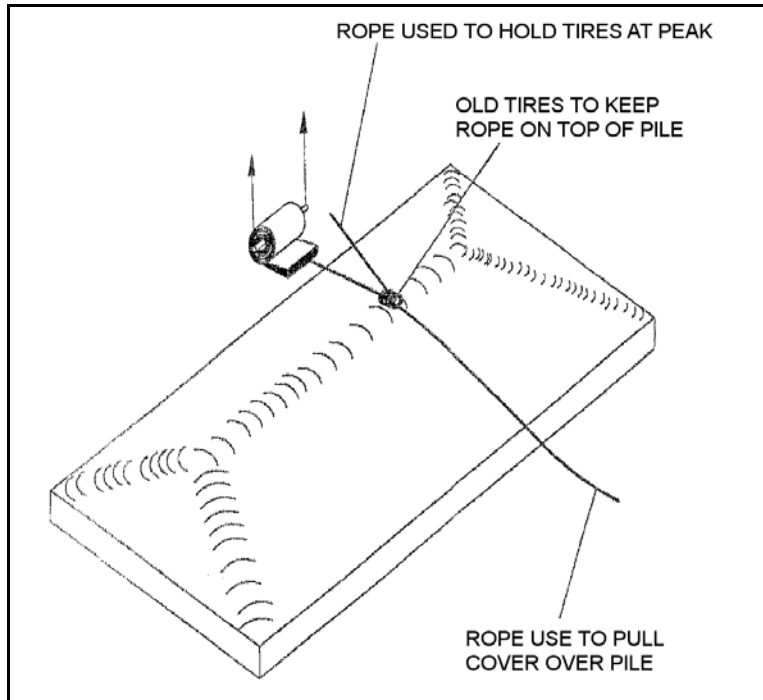

**Figure 4.2**

3. Pull on the rope, raising the cover to the peak; release the rope holding the tires, letting them come over with the cover. See Figure 4.3.

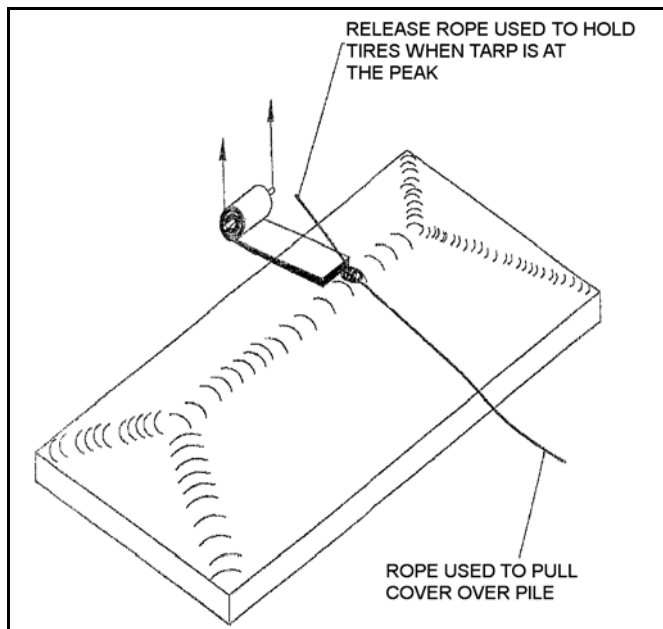

**Figure 4.3**

4. Position 6 to 8 people across the cover and pull it out to cover two thirds of the pile. Then, do the same with the last one third of the pile. Pull cover tight. Turn on the fans. See Figure 4.4.

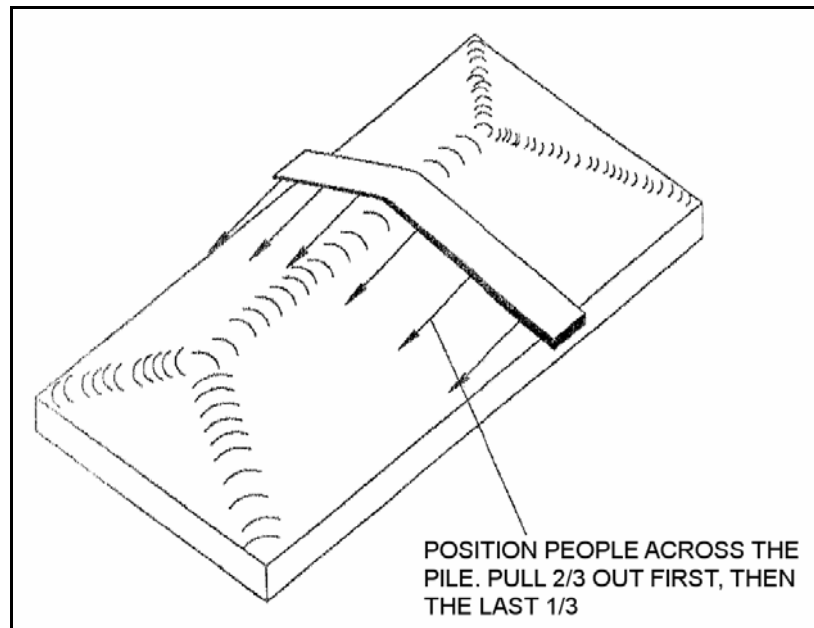

**Figure 4.4**

5. Trim cover so that it has about a 60 cm overhang. Wrap a 5 cm x 10 cm piece of lumber in the edge of the cover as a batten strip and screw or nail it to the bunker wall.



## LIMITED WARRANTY

Seller warrants that all of the goods sold hereunder will conform to their description in Seller's published literature current at the time the Buyer's order is accepted, that Seller will use good material and workmanship in the manufacture of such goods, and that such goods will conform to applicable laws and regulations regarding purity.

Seller will repair or replace, at its discretion, any nonconforming goods (or refund their purchase price at Seller's option), but only if Seller receives written notice of nonconformity within 60 days after shipment and Buyer's remedies hereunder are expressly so limited.

**Seller makes no other warranties of any kind with respect to such goods or any part thereof, express or implied. All implied warranties of merchantability and fitness for a particular purpose are hereby disclaimed by seller and excluded from this agreement, and such goods are sold "as is" and with all faults.**

**Seller will have no liability for consequential damages of any kind, including damages arising from bodily injury or the loss of use of such goods or other property. Buyer releases all claims for such damages, whether based on contract, warranties, strict liability, or negligence.**



# **union iron**

601 S. 27th Street

P.O. Box 1038

Decatur, IL 62525 USA

Phone: (217) 429-5148

Fax: (217) 429-5149

Website: [www.unionironworks.com](http://www.unionironworks.com)