



GRAIN
HANDLING
SYSTEMS

Huss & Schlieper Inc.

ELECTRIC DISTRIBUTOR

MODEL DR
ASSEMBLY & OPERATION



Read this manual before using product. Failure to follow instructions and safety precautions can result in serious injury, death, or property damage. Keep manual for future reference.

Part Number: IEDM0308-R0

Revised: Aug/08

TABLE OF CONTENTS

1. Introduction	5
2. Safety First.....	7
2.1. General Safety	9
2.2. Installation Safety	9
2.3. Operational & Maintenance Safety.....	10
2.3.1. Lockout and Tagout Procedures	10
2.4. Safety Decal Locations.....	10
2.4.1. Decal Installation	11
2.4.2. Decal Locations	11
3. Assembly	13
3.1. General Assembly	13
3.2. Electric Distributor Calibration	15
4. Operation	19
4.1. General Operation	20
4.2. Shutdown	20
5. Maintenance	21
5.1. Parts Maintenance	21
5.2. Bearing and Support Shaft	22
6. Troubleshooting	23
7. Appendix.....	25
7.1. Drive Parameters	25
7.2. Logic Inputs	25
7.3. Speed Settings	26
7.4. Turnhead Controller Diagrams	27
7.5. PLC Interface	30
Limited Warranty	31

1. Introduction

Congratulations on your purchase of an HSI Systems Model DR Electric Distributor. This distributor is a dust-tight, weather-proof enclosure that uses an AC brakemotor, proximity switches, and encoder in a dust-free, automatic control panel housing with a variable frequency drive.

The DR Electric Distributor has internal spouts revolving on lower ball bearings and upper roller bearings and is designed to be easily removed and replaced. The dual redundant automatic control panel features a touch screen to select and indicate the outlet position.

Before using the distributor, give this manual to the people who will be operating and maintaining this equipment. Reading and understanding this manual will reduce downtime and equipment failure, as well as ensure safe and efficient operation. A sign-off form is provided on the inside front cover for your convenience.

The serial number plate is located on the inspection door. Please mark the number in the space provided for easy reference.

Model#	
Serial #	
Production Year	

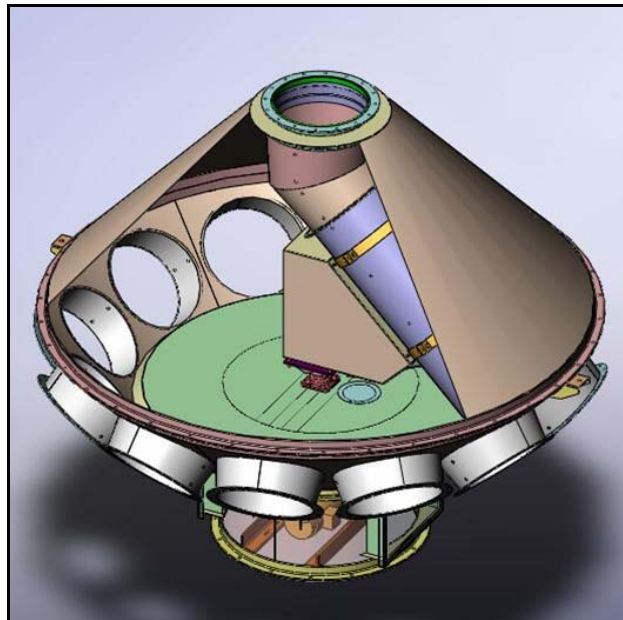

2. Safety First

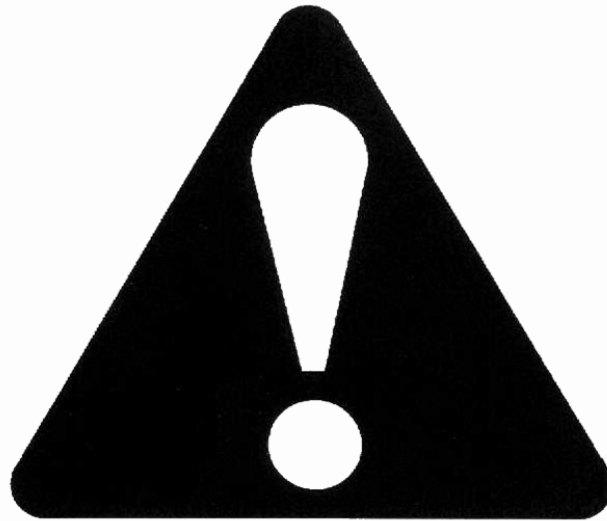

The Safety Alert symbol identifies important safety messages on the product and in the manual. When you see this symbol, be alert to the possibility of personal injury or death. Follow the instructions in the safety messages.

Why is SAFETY important to you?

Three big reasons:

- Accidents disable and kill.
- Accidents cost.
- Accidents can be avoided.

SIGNAL WORDS

Note the use of the signal words **DANGER**, **WARNING**, **CAUTION**, and **NOTICE** with the safety messages. The appropriate signal word for each message has been selected using safety as a guideline.

This Safety Alert symbol means ATTENTION, BE ALERT!, YOUR SAFETY IS INVOLVED.

DANGER

DEFINITION: Indicates an imminently hazardous situation that, if not avoided, will result in serious injury or death. This signal word is limited to the most extreme situations.

WARNING

DEFINITION: Indicates a hazardous situation that, if not avoided, could result in serious injury or death.

CAUTION

DEFINITION: Indicates a hazardous situation that, if not avoided, may result in minor or moderate injury.

NOTICE

DEFINITION: Indicates a potentially hazardous situation that, if not avoided, may result in property damage.

YOU are responsible for the **SAFE** use and maintenance of your product. **YOU** must ensure that you and anyone else who is going to work around the product be familiar with all procedures and related **SAFETY** information contained in this manual.

Remember, **YOU** are the key to safety. Good safety practices not only protect you, but also the people around you. Make these practices a working part of your safety program.

- Product owners must give instructions to employees before allowing them to operate or use the product.
- The most important safety device on this product is a **SAFE** user or operator. It is the user/operator's responsibility to read and understand

ALL safety instructions in the manual and to follow them. All accidents can be avoided.

- A person who has not read and understood all safety instructions is not qualified to operate or use the product. Untrained users/operators expose themselves and bystanders to possible serious injury or death.
- Do not modify the product in any way. Unauthorized modification may impair the function and/or safety, and could affect the life of the product. Any modification to the product voids the warranty.
- Use this product for its intended purposes only.
- Think SAFETY! Work SAFELY!

2.1. GENERAL SAFETY

Important: *The general safety section includes instructions that apply to all safety practices. Any instructions specific to a certain safety practice (e.g. assembly safety), can be found in the appropriate section.*



- Read and understand all safety instructions, safety decals, and manual(s) before assembling or operating equipment.
- Only trained, competent people shall operate or use the product. An untrained operator is not qualified to operate equipment.
- Have a first-aid kit available for use should the need arise, and know how to use it.
- Provide a fire extinguisher for use in case of an accident. Store in a highly visible place.
- Do not allow children, spectators, or bystanders within the work area.



- Wear appropriate protective gear. This list includes, but is not limited to:

- a hard hat
- protective shoes with slip-resistant soles
- protective goggles
- hearing protection



- For powered products: before servicing, adjusting, or repairing, unplug, place all controls in neutral or off position, stop the engine or motor, remove ignition key or lock out power source, and wait for all moving parts to stop.
- Review safety information initially and annually with all personnel who will be using the product.
- Follow good shop practices:
 - Keep service area clean and dry.
 - Be sure electrical outlets and tools are properly grounded.
 - Use adequate light for the job at hand.



2.2. INSTALLATION SAFETY

- All equipment should be checked for damage immediately upon arrival. Do not attempt to install a damaged item.
- Have 2 people handle the heavy, bulky components.

2.3. OPERATIONAL & MAINTENANCE SAFETY

Electrical controls, machinery guards, railings, walkways, arrangement of installation, training of personnel, etc., are necessary for a safe working environment. It is the responsibility of the contractor, installer, owner, and user to supplement the materials and services furnished with the necessary items to make the equipment installation comply with the law and accepted standards.

- Guards, access doors, and covers must be securely fastened before operating this equipment.
- Do not place hands or feet in any of the openings while equipment is running.
- Do not push or force material into the distributor.
- Do not overload distributor or use it for anything other than its intended use.
- Inspect all parts. Ensure parts are in good condition and installed properly.

2.4. LOCKOUT AND TAGOUT PROCEDURES

To minimize possibility of serious injury or death to workers from hazardous energy release (for example, when restarting the equipment) and prevent worker deaths from all forms of hazardous energy release (restarting of equipment), we recommend that you follow all lockout and tagout procedures when installing and servicing equipment. Ensure that all OSHA procedures are adhered to, for example:

- De-energize, block, and dissipate all sources of hazardous energy.
- Lock out and/or tag out all forms of hazardous energy.
- Ensure that only 1 key exists for each assigned lock, and that you are the only one that holds that key.
- After verifying all energy sources are de-energized, service or installation may be performed.
- Ensure that all personnel are clear before turning on power to equipment.

For more information on occupational safety practices, see www.osha.gov.

2.5. SAFETY DECAL LOCATIONS

- Keep safety decals clean and legible at all times.
- Replace safety decals that are missing or have become illegible.
- Replaced parts must display the same decal(s) as the original part.
- Safety decals are available from your distributor, dealer, or factory.

2.5.1. DECAL INSTALLATION

1. Installation area must be clean and dry, with a temperature above 10°C (50°F).
2. Decide on the exact position before you remove the backing paper.
3. Align the decal over the specified area and carefully press the small portion with the exposed sticky backing in place.
4. Slowly peel back the remaining paper and carefully smooth the remaining portion of the decal in place.
5. Small air pockets can be pierced with a pin and smoothed out using the piece of sign backing paper.

2.5.2. DECAL LOCATIONS

The types of safety decals and locations on the equipment are shown below. Good safety requires that you familiarize yourself with the various safety decals, the type of warning, and the area or particular function related to that area that requires your **SAFETY AWARENESS**.



PLACE GENERAL WARNING (P200-0017) AND CE DECALS (P200-0020) IN A CONVENIENT LOCATION ON THE EQUIPMENT.



PLACE ELECTROCUTION HAZARD (P200-0019) ON THE COVERS OF THE JUNCTION MAIN BOX AND MAIN CONTROL PANEL

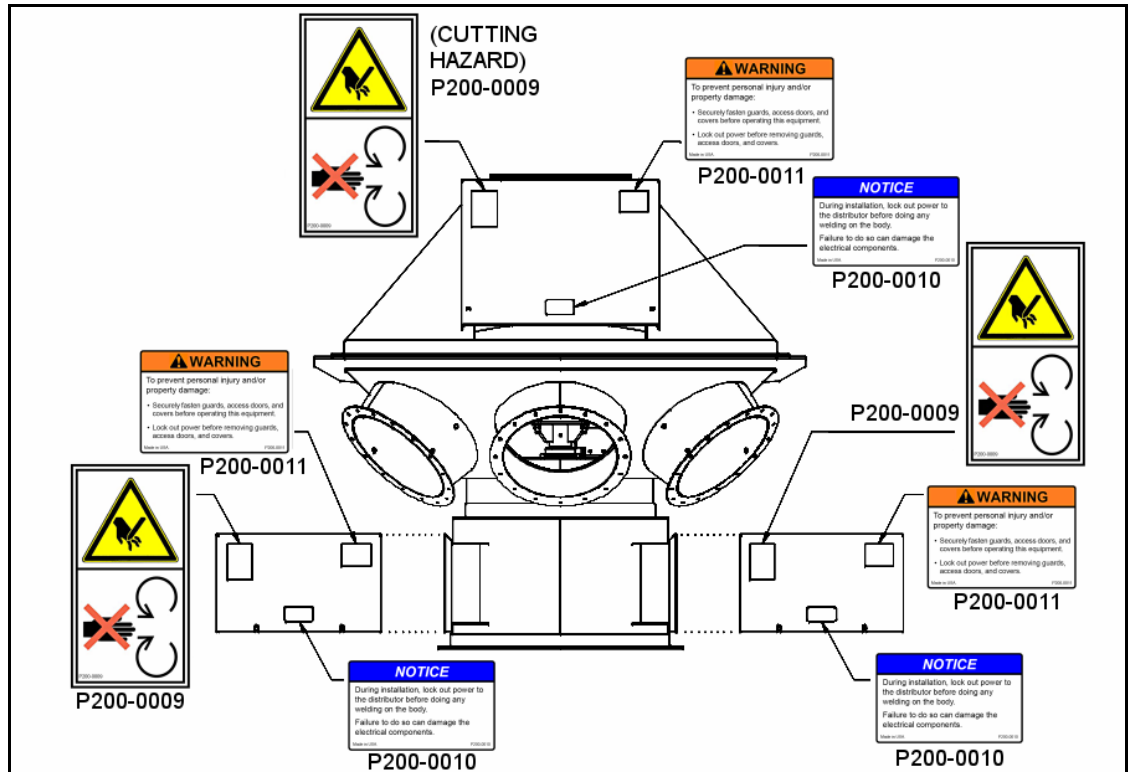

Figure 2.1 Safety Decal Placement

3. Assembly

WARNING

Before continuing, please reread the safety information relevant to this section at the beginning of this manual. Failure to follow the safety instructions can result in serious injury, death, or property damage.

NOTICE

Adequate surge suppression is required on the incoming 110/120V AC supply line to protect the processor and is usually not supplied by the factory. Please consult with your electrician for your specific requirements.

3.1. GENERAL ASSEMBLY

See Figure 3.1 and 3.2.

1. Ensure all parts are present and in good condition before beginning assembly. The size of the distributor received will determine how many sections will need to be assembled.
2. If unit is to rest on a sub-structure, position anchor pads on the lower housing.
3. Insert bolts, nuts, and washers, but do not tighten; this will eliminate undue stress and will ease assembly.
4. Continue to assemble all remaining components according to the matching marks on the assembly drawing if the distributor has been shipped in sections.
5. After components are in place, tighten all bolts.
6. Tighten anchor pads to sub-structure.

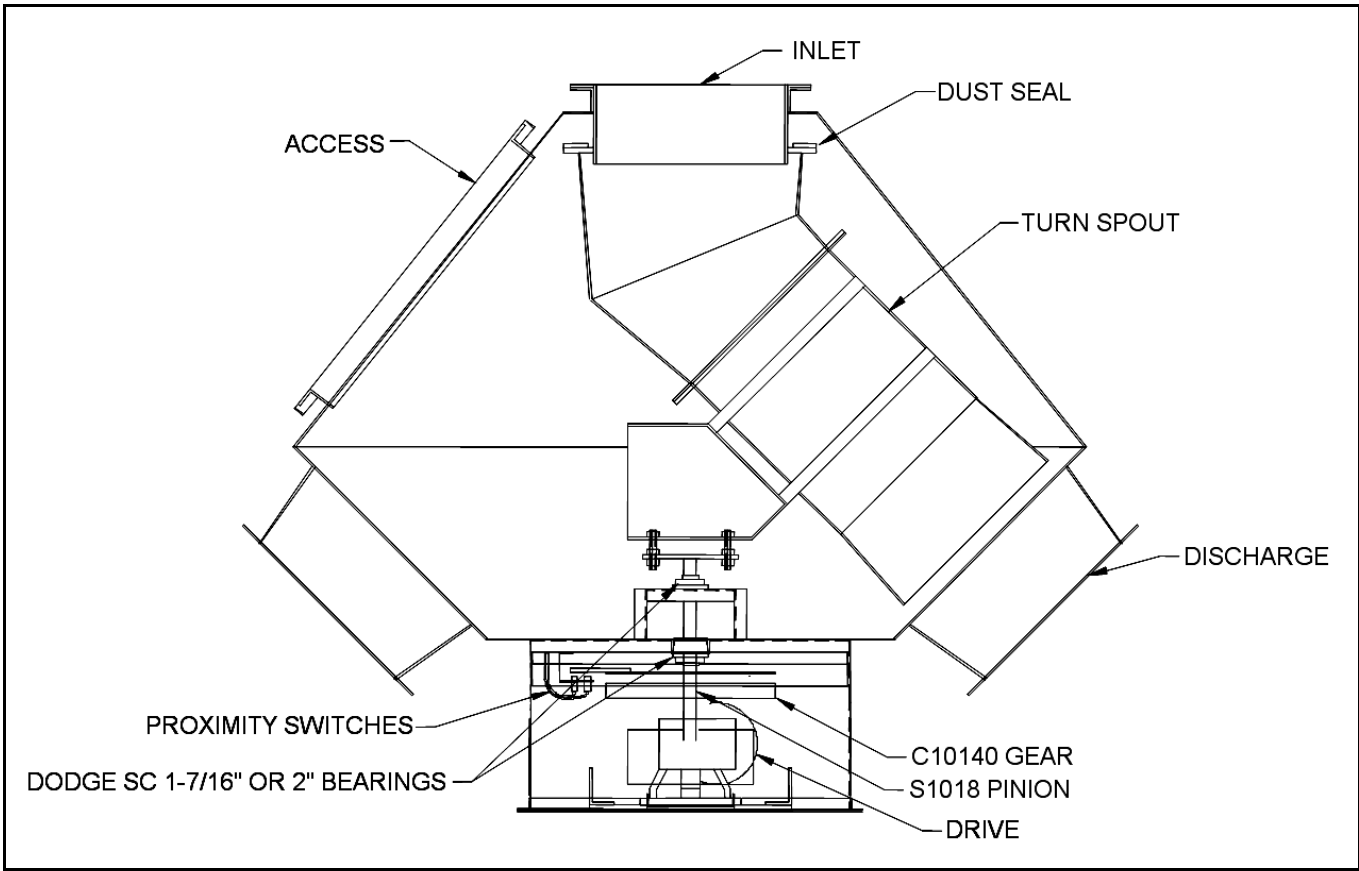

Figure 3.1 Electric Single Distributor

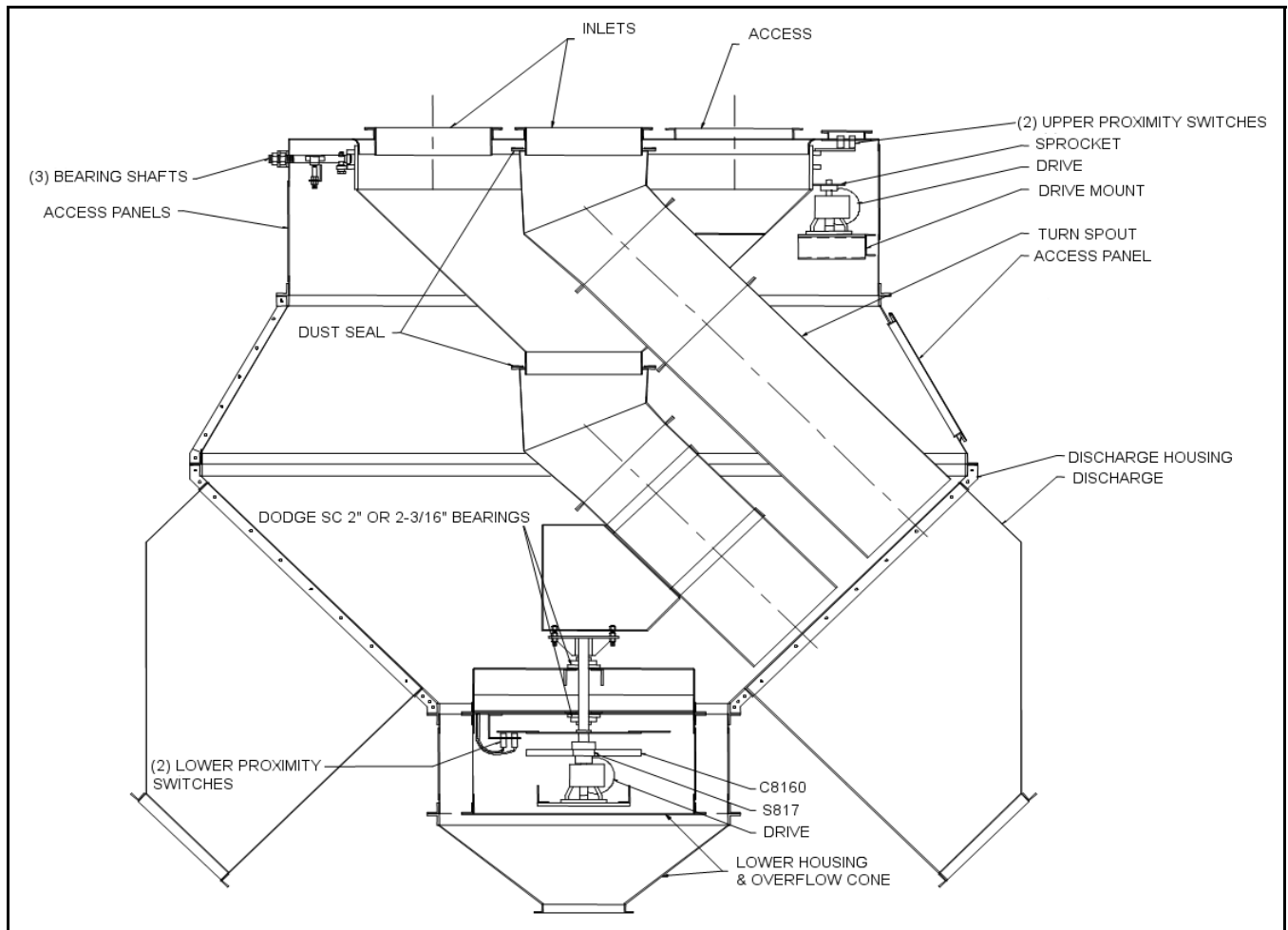

Figure 3.2 Electric Double Distributor

3.2. ELECTRIC DISTRIBUTOR CALIBRATION

See Figure 3.3 and Figure 3.4.

Calibration is preset during fabrication and should not need to be reset unless new components are installed or the speed of the unit is changed from the factory setting.

Note: *Calibration is best completed with 2 people: one at the panel, and one watching the position of the turn spout in relation to the discharge port opening.*



Figure 3.3 Control Panel



Figure 3.4 Control Panel Close-Up

To CALIBRATE:

1. Place jumper cable block on both prongs labeled J1 on the circuit board in the main panel.
2. Turn unit on. Press enter to calibrate. The read-out screen will be searching for home, and then it will register the number of ports on the distributor.
3. When all ports register, panel will go into "Checking Deceleration" mode. After it is finished, the screen will display a "Calibration Complete" message. Press enter to set offsets.
4. Select Port 2 and press enter. The head will rotate to position 2. Have the person watching the ports tell you when and where the rotation stops. If the head needs to be adjusted, press the arrow buttons on the panel until it reaches the desired position.
5. After the head is in position, write down the number that appears on the screen (for example, 0035 or -0028). After you've written the number down, press enter.

Note: *HSI Systems can use these numbers to rename the ports for your convenience (ports come named by number, but can be renamed if you like; for example, you can change Port 1 to Loadout Bin, or Port 2 to Wet Bin.)*

6. The screen will give you the choice to exit or to move to the next port. Press enter and select the next port, then press enter again.
7. Repeat steps 4-6 to set the offsets for the rest of the ports.
8. When all the ports have been set, go to Port 1. **Port 1 should be calibrated last.**
9. After the last port position has been recorded, press enter. You will be given a choice to exit or go to the next port. Push the select button to exit. The screen will display a "Calibration Offsets Complete" message. Turn the power off and wait for 2 to 3 minutes.
10. While the power is off, remove the jumper block from both prongs labeled J1 on the circuit board in the main panel, and place the jumper block on only one prong. Either of the prongs is acceptable.
11. Turn the power back on. The screen should display a port number. To move to that port, press enter and select. Select the desired port. Press enter. You are now in run mode. To select another port, press enter and select.
12. Now you may select any port and press the enter button to move to that position. The head will make one complete revolution before stopping at the port you have chosen.
13. Double-check that the port and position match the readout on the screen.

You are now ready to begin running product through this unit.

4. Operation

WARNING

Before continuing, please reread the safety information relevant to this section at the beginning of this manual. Failure to follow the safety instructions can result in serious injury, death, or property damage.



Figure 4.1 Control Panel



Figure 4.2 Control Panel Close-Up

4.1. GENERAL OPERATION

The Model DR Electric Distributor is very simple and straightforward to operate:

1. At start-up, the spout will rotate a complete 360° to find its home position.
2. The operator simply selects the desired port on the touch screen and presses enter.
3. The revolving spout will rotate to desired port, the touch screen will indicate that movement, and the desired port location will be displayed on the screen.

Note: *Instructions for operation are printed on the panel faceplate for the operator's convenience.*

WARNING	
	To prevent personal injury and/or property damage, securely fasten guards, access doors, and covers before operating this equipment. Also lock out power before removing guards, access doors, and covers.

WARNING	
	Cutting hazard! To prevent serious injury, keep hands clear when machine is operating.

4.2. SHUTDOWN

1. Allow distributor to empty completely before shutting down to avoid grain contamination.
2. Allow distributor to come to a complete stop and lock out power before performing any maintenance on the unit.

5. Maintenance

WARNING

Before continuing, please reread the safety information relevant to this section at the beginning of this manual. Failure to follow the safety instructions can result in serious injury, death, or property damage.

Regular maintenance is instrumental in reducing downtime and equipment failure. Operators and maintenance personnel should read and understand the instructions in this section. Proper maintenance will ensure many years of safe, economical, and trouble-free operation.

CAUTION



Before performing any internal inspections or maintenance on the distributor, ensure that a mechanical lockout is in place on the motor starter.

During maintenance you will have to remove various service and inspection doors. These **doors must be reinstalled** before operating the distributor.

Important: *Drive sprockets and chain should be inspected every six months.*

5.1. PARTS MAINTENANCE

MOTORS

Motors are properly lubricated at the time of manufacture; it is not necessary to lubricate them at the time of installation.

- If a motor has been in storage for a period of 6 months or more, lubricate before starting.
- Lubrication should be checked every 12 months.
- Lubricate with NGLI grade 2 type grease as required.

REDUCERS

Reducers are lubricated for life with lubrication oil: Mobil SHC 634, or equivalent.

- Base gear units are supplied with oil good from 32°-122°F (0°-50°C). A colder environment will require an oil similar to Mobil SHC 630 (synthetic oil rated for -22°F or -30°C).
- If a reducer is to be stored, or if it has been inactive after installation for a period longer than 6 months, drain oil from housing. Spray all internal parts

with a rust-preventative oil that is soluble in lubricating oil, or add “MotorS-tor” vapor rust inhibitor.

DRIVE

Distributors are usually furnished with either a 1/2 hp or 1 hp gear unit depending on the size of the distributor.

- 1750 rpm AC motor, 56C frame
- Textron gearbox:
 - a. Textron B051050HAQTN 50:1 ratio gearbox for single electric and lower double electric drives with high base kit.
 - b. Textron B0520 100:1 ratio gearbox for upper double electric drives with high base kit.

5.2. BEARING AND SUPPORT SHAFT

The size of the bearing and support shaft depends on the size of the internal spout, the number of outlets, and the diameter of the distributor.

One of the following size bearings will be used depending on the size of the distributor.

Single	
2	1-7/16” or 2” diameter Dodge SC (or equivalent) flange bearing
1	C10140 Martin gear 1-7/16” or 2” bore
1	S10020 Martin pinion with 1” bore, 1/4” KW

Double	
2	2” or 2-3/16” diameter Dodge SC (or equivalent) flange bearing
1	C8160 Martin gear 2” or 2-3/16” bore
1	C817 Martin pinion with 1” bore, 1/4” KW
3-4	L-12 Seal Master bearings

6. Troubleshooting

Table 6.1 Equipment Troubleshooting

Problem	Cause	Solution
Motor is operating but drive is not engaging.	• Faulty reducer.	• Replace reducer.
	• Broken coupling.	• Repair coupling.
Bearings are making unusual noise.	• Bearing is probably improperly lubricated.	• Refer to service manual and lubricate properly.
	• Bearing is damaged.	• Repair or replace.
Reducer is making an unusual noise.	• Excessive gear wear.	• Refer to parts manual and replace gear.
	• Insufficient lubrication.	• Refer to service manual and lubricate properly.
Discharge spouts misalign with the discharge ports.	• Sensing disc for proximity switches has moved.	• Realign and tighten.

Table 6.2 Grain Head Error Code Chart

Error Number	Display Text	Notes	Solution
0	ENABLE NOT MADE	• Enable input is not high enough.	• Reset enable input.
1	UNIT NOT MOVING	• Unit tried to move but encoder did not change value.	• Check for loose motor leads on terminal strip in main panel.
			• Check for loose connections on circuit board
2	RUNNING WRONG DIRECTION	• Encoder value changing in the wrong direction	• Change two motor leads in main panel
3	HOME PROX NOT FOUND	• Home prox input is always high	• Make sure home prox aligns with target disc
4	HOME PROX ALWAYS MADE	• Home prox input is always low	• Reposition position prox
5	POSI PROX NOT FOUND	• Position prox is always high	• Reposition position prox
6	POSI PROX ALWAYS MADE	• Position prox is always low	• Prox wires are reversed in terminal strip
			• Unit not running at correct speed

Table 6.2 Grain Head Error Code Chart

Error Number	Display Text	Notes	Solution
7	NO COMMUNICATIONS	<ul style="list-style-type: none"> • Communications link is down. 	<ul style="list-style-type: none"> • Nicked wire or loose wires in terminal strip.
			<ul style="list-style-type: none"> • Communication cable ran in conduit with power wires.
8	ENCODING ERROR	<ul style="list-style-type: none"> • Calibration values in memory do not match encoder readings. 	<ul style="list-style-type: none"> • Possible causes are changing drive speed after calibration, bad encoder, poor mechanical connection to encoder, brake not holding, or poor linkage between brake and encoder.
9	ENCODER PROX MISMATC	<ul style="list-style-type: none"> • Calibration values in memory do not match encoder readings. 	<ul style="list-style-type: none"> • Possible causes are changing drive speed after calibration, bad encoder, poor mechanical connection to encoder, brake not holding, or poor linkage between brake and encoder.
10	REMOTE REF	<ul style="list-style-type: none"> • The values coming from the remote board are not correct. 	<ul style="list-style-type: none"> • Remote board has reset, likely because of intermittent power connection or high electrical noise.

7. Appendix

7.1. DRIVE PARAMETERS

Table 7.1 Drive Parameters^a

	Single and Lower Double Drive	Upper Double Drive
bFr	60 Hz under drC	60 Hz under drC
tFr	60 Hz under drC	60 Hz under drC
SP2	2 Hz under SEt	8 Hz under SEt
SP3	10 Hz under SEt	20Hz under SEt ^b
SP4	60 Hz under SEt	60 Hz under SEt
Frt	5 Hz under Fun-fPc-Frt	5 Hz under Fun-fPc-Frt
ACC	0.1 under SEt	0.1 under SEt
ACC2	0.5 under SEt	1.5 under SEt
DEC2	0.5 under SEt	1.5 under SEt
DECC	0.1 under SEt	0.1 under SEt

- a. If you wish to slow the rotation of the turnhead, you can set SP4 anywhere between 40Hz to 60Hz. Please note the changes in your file and email them to blake@unionironworks.com so that the changes to the permanent records can be made.
- b. Varies depending on size and number of holes for unit. Any time a setting is changed, the unit must be recalibrated.

7.2. LOGIC INPUTS

Table 7.2 Factory default settings on logic inputs

LI1	FWD
LI2	REV
LI3	Bit0
LI4	Bit1

7.3. SPEED SETTINGS

Table 7.3 Factory default setting for speeds

1	0Hz
2	10Hz
3	15Hz
4	20Hz

7.4. TURNHEAD CONTROLLER DIAGRAMS

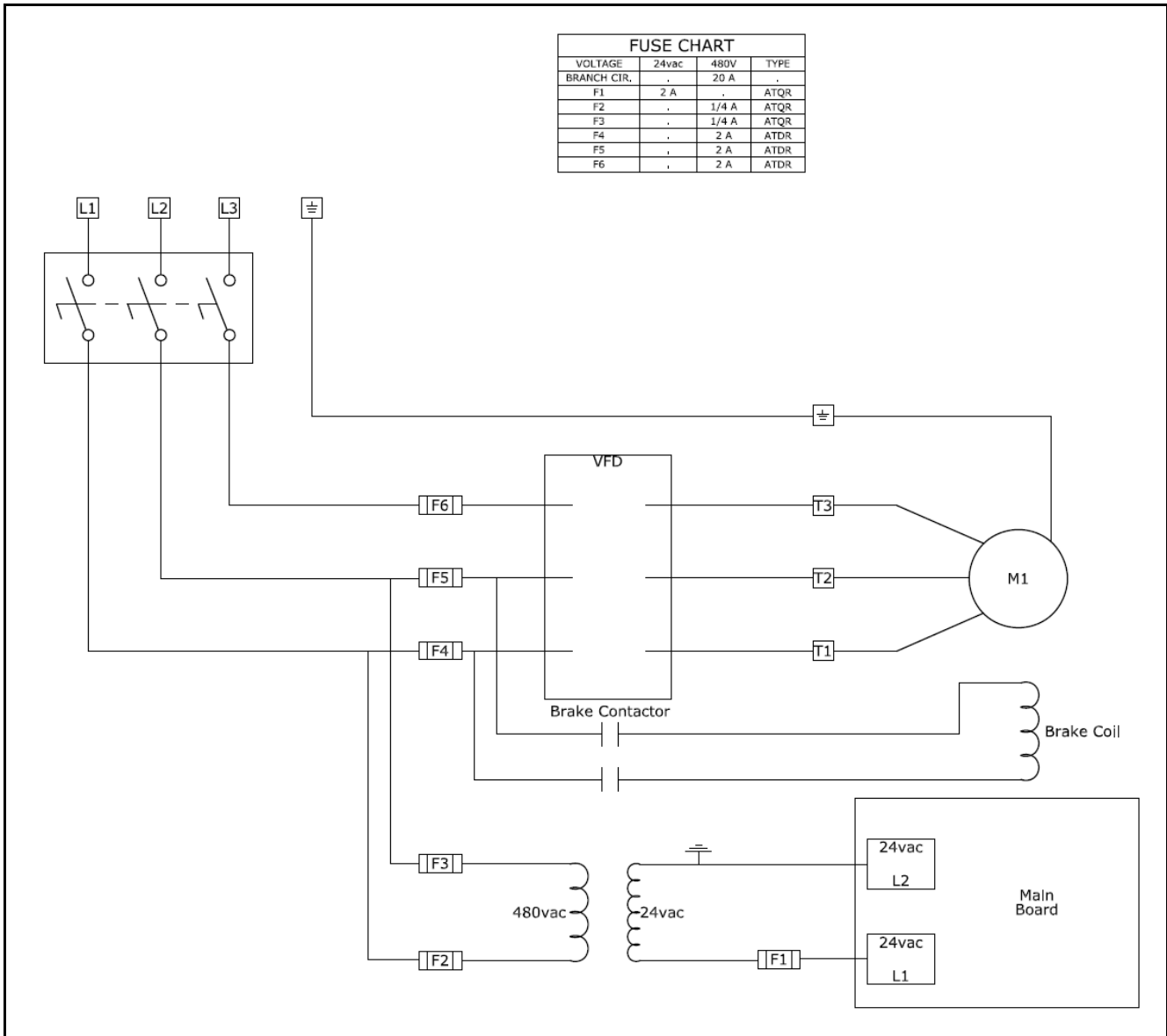

Figure 7.1 Turnhead Controller 9000-1220 Power Diagram

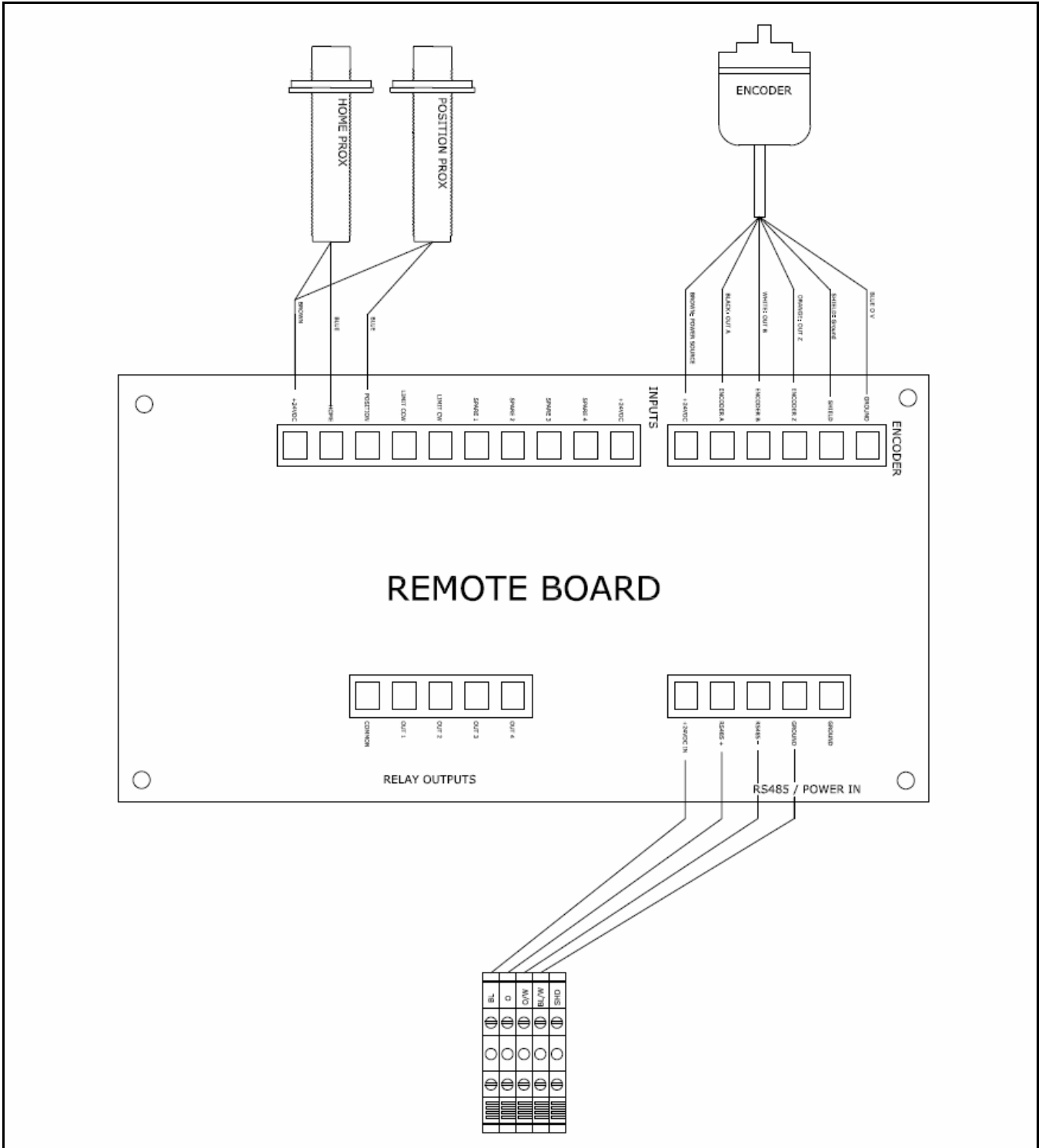

Figure 7.2 Turnhead Controller 9000-1220 Remote Board

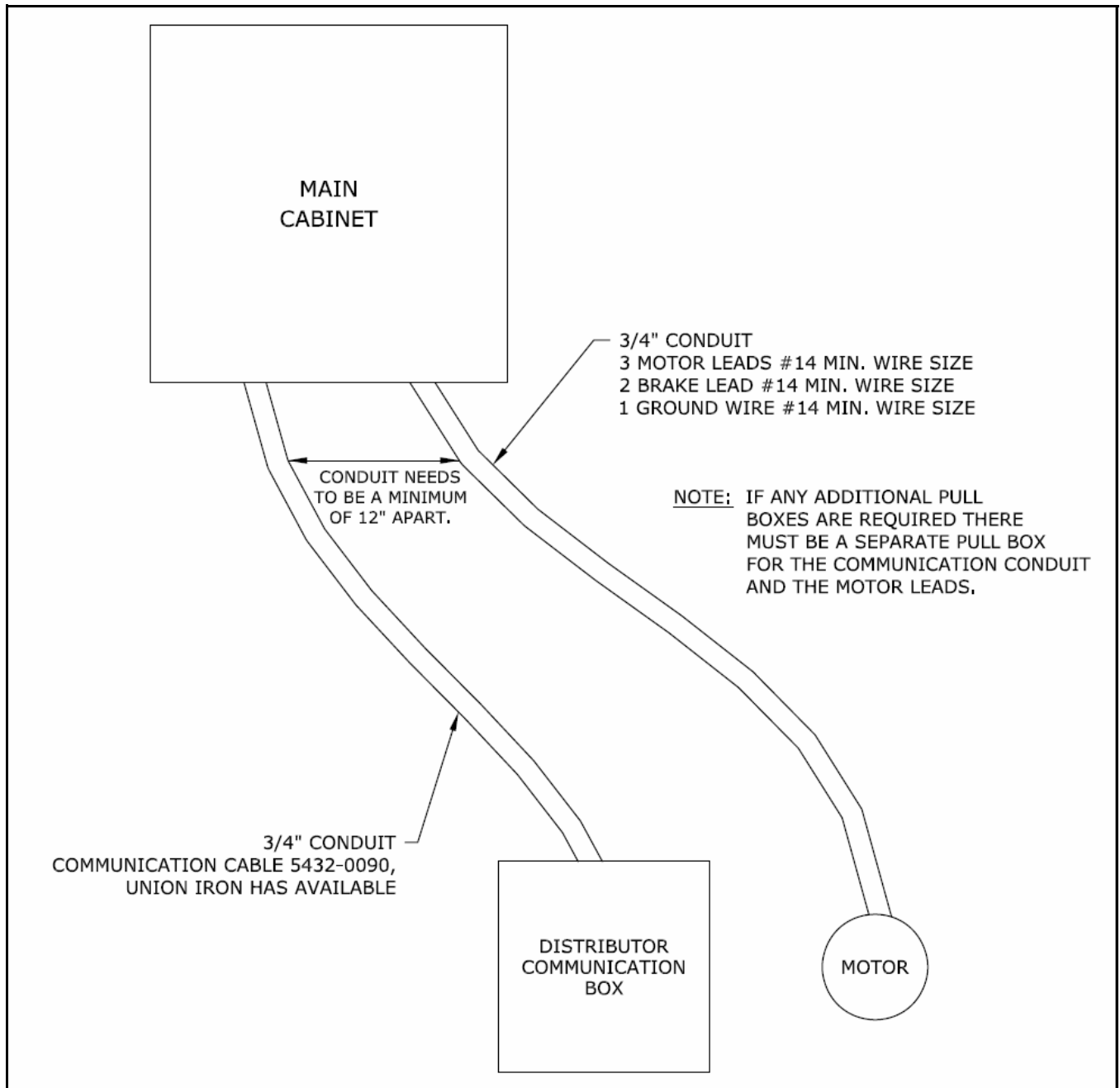

Figure 7.3 Turnhead Controller 9000-1220 Field Wiring

7.5. PLC INTERFACE

Board Inputs from PLC Outputs						Board Outputs to PLC Inputs					
After the position has been selected, there needs to be an output from the PLC to the PCL Move input on the turn head PC Board.						Once the turn head has reached the position selected, it will give a binary output of its position and the board output "DONE" will turn on.					
PLC Output	First	Second	Third	Fourth	Fifth	PC Board PLC Interface Output	Data 0	Data 1	Data 2	Data 3	Data 4
Selected Position						Turn Head Position					
1	X					1	X				
2		X				2		X			
3	X	X				3	X	X			
4			X			4			X		
5	X		X			5	X		X		
6		X	X			6		X	X		
7	X	X	X			7	X	X	X		
8				X		8				X	
9	X			X		9	X			X	
10		X		X		10		X		X	
11	X	X		X		11	X	X		X	
12			X	X		12			X	X	
13	X		X	X		13	X		X	X	
14		X	X	X		14		X	X	X	
15	X	X	X	X		15	X	X	X	X	
16					X	16					X
17	X				X	17	X				X
18		X			X	18		X			X
19	X	X			X	19	X	X			X
20			X		X	20			X		X
21	X		X		X	21	X		X		X
22		X	X		X	22		X	X		X
23	X	X	X		X	23	X	X	X		X
24				X	X	24				X	X
25	X			X	X	25	X			X	X
26		X		X	X	26		X		X	X
27	X	X		X	X	27	X	X		X	X
28			X	X	X	28			X	X	X
29	X		X	X	X	29	X		X	X	X
30		X	X	X	X	30		X	X	X	X
31	X	X	X	X	X	30	X	X	X	X	X

LIMITED WARRANTY

Seller warrants that all of the goods sold hereunder will conform to their description in Seller's published literature current at the time the Buyer's order is accepted, that Seller will use good material and workmanship in the manufacture of such goods, and that such goods will conform to applicable laws and regulations regarding purity.

Seller will repair or replace, at its discretion, any nonconforming goods (or refund their purchase price at Seller's option), but only if Seller receives written notice of nonconformity within 60 days after shipment and Buyer's remedies hereunder are expressly so limited.

Seller makes no other warranties of any kind with respect to such goods or any part thereof, express or implied. All implied warranties of merchantability and fitness for a particular purpose are hereby disclaimed by seller and excluded from this agreement, and such goods are sold "as is" and with all faults.

Seller will have no liability for consequential damages of any kind, including damages arising from bodily injury or the loss of use of such goods or other property. Buyer releases all claims for such damages, whether based on contract, warranties, strict liability, or negligence.



Huss & Schlieper Inc.

602 S. 27th Street

P.O. Box 1038

Decatur, IL 62525 USA

Phone: (217) 429-5148

Fax: (217) 429-5149

website: www.hsisystems.com