



GRAIN
HANDLING
SYSTEMS

Huss & Schlieper Inc.

MANUAL DISTRIBUTOR
ALL MODELS
ASSEMBLY & OPERATION MANUAL



Read this manual before using product. Failure to follow instructions and safety precautions can result in serious injury, death, or property damage. Keep manual for future reference.

Part Number: IMDM0608-R0

Revised: Dec/08

TABLE OF CONTENTS

1. Introduction	5
2. Safety First.....	7
2.1. General Safety	10
2.2. Installation Safety	10
2.3. Operational & Maintenance Safety.....	11
2.4. Lockout and Tagout Procedures	11
2.5. Safety Decal Locations.....	11
2.5.1. Decal Installation	12
2.5.2. Decal Locations	12
3. Assembly	15
4. Operation	17
5. Maintenance	19
5.1. Bearing and Support Shaft	19
6. Troubleshooting	21
Limited Warranty	23

1. Introduction

Congratulations on your purchase of an HSI Systems Manual Distributor. This distributor is a dust-tight, weather-proof enclosure that uses a manual turn spout wheel with slide drop seal to ensure positive location of the turn spout.

The internal spout revolves on ball bearings and is easily removable and replaceable if ever necessary.

Before using the distributor, give this manual to the people who will be operating and maintaining this equipment. Reading and understanding this manual will reduce downtime and equipment failure, as well as ensure safe and efficient operation. A sign-off form is provided on the inside front cover for your convenience.

2. Safety First

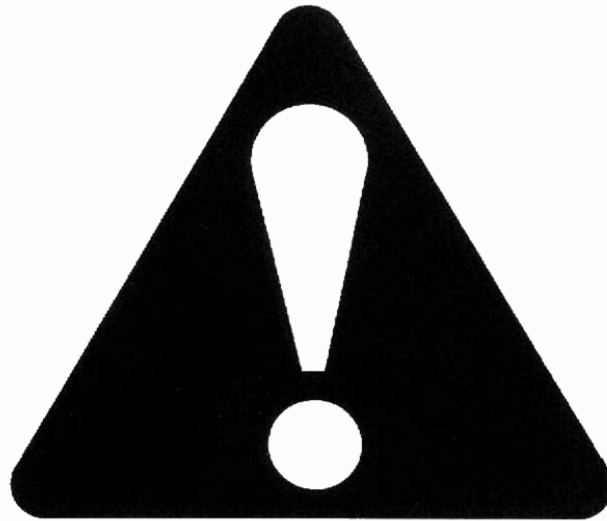

The Safety Alert symbol identifies important safety messages on the product and in the manual. When you see this symbol, be alert to the possibility of personal injury or death. Follow the instructions in the safety messages.

Why is SAFETY important to you?

Three big reasons:

- Accidents disable and kill.
- Accidents cost.
- Accidents can be avoided.

SIGNAL WORDS

Note the use of the signal words **DANGER**, **WARNING**, **CAUTION**, and **NOTICE** with the safety messages. The appropriate signal word for each message has been selected using safety as a guideline.

This Safety Alert symbol means ATTENTION, BE ALERT!, YOUR SAFETY IS INVOLVED.

DANGER

DEFINITION: Indicates an imminently hazardous situation that, if not avoided, will result in serious injury or death. This signal word is limited to the most extreme situations.

WARNING

DEFINITION: Indicates a hazardous situation that, if not avoided, could result in serious injury or death.

CAUTION

DEFINITION: Indicates a hazardous situation that, if not avoided, may result in minor or moderate injury.

NOTICE

DEFINITION: Indicates a potentially hazardous situation that, if not avoided, may result in property damage.

YOU are responsible for the **SAFE** use and maintenance of your product. **YOU** must ensure that you and anyone else who is going to work around the product be familiar with all procedures and related **SAFETY** information contained in this manual.

Remember, **YOU** are the key to safety. Good safety practices not only protect you, but also the people around you. Make these practices a working part of your safety program.

- Product owners must give instructions to employees before allowing them to operate or use the product.
- The most important safety device on this product is a **SAFE** user or operator. It is the user/operator's responsibility to read and understand

ALL safety instructions in the manual and to follow them. All accidents can be avoided.

- A person who has not read and understood all safety instructions is not qualified to operate or use the product. Untrained users/operators expose themselves and bystanders to possible serious injury or death.
- Do not modify the product in any way. Unauthorized modification may impair the function and/or safety, and could affect the life of the product. Any modification to the product voids the warranty.
- Use this product for its intended purposes only.
- Think SAFETY! Work SAFELY!

2.1. GENERAL SAFETY

Important: *The general safety section includes instructions that apply to all safety practices. Any instructions specific to a certain safety practice (e.g. assembly safety), can be found in the appropriate section.*



- Read and understand all safety instructions, safety decals, and manual(s) before assembling or operating equipment.
- Only trained, competent people shall operate or use the product. An untrained operator is not qualified to operate equipment.
- Have a first-aid kit available for use should the need arise, and know how to use it.
- Provide a fire extinguisher for use in case of an accident. Store in a highly visible place.



- Do not allow children, spectators, or bystanders within the work area.
- Wear appropriate protective gear. This list includes, but is not limited to:

- a hard hat
- protective shoes with slip-resistant soles
- protective goggles
- hearing protection



- For powered products: before servicing, adjusting, or repairing, unplug, place all controls in neutral or off position, stop the engine or motor, remove ignition key or lock out power source, and wait for all moving parts to stop.
- Review safety information initially and annually with all personnel who will be using the product.
- Follow good shop practices:
 - Keep service area clean and dry.
 - Be sure electrical outlets and tools are properly grounded.
 - Use adequate light for the job at hand.



2.2. INSTALLATION SAFETY

- Check all equipment for damage immediately upon arrival. Do not attempt to install a damaged item.
- Have 2 people handle the heavy, bulky components.

2.3. OPERATIONAL & MAINTENANCE SAFETY

Electrical controls, machinery guards, railings, walkways, arrangement of installation, training of personnel, etc., are necessary for a safe working environment. It is the responsibility of the contractor, installer, owner, and user to supplement the materials and services furnished with the necessary items to make the equipment installation comply with the law and accepted standards.

- Guards, access doors, and covers must be securely fastened before operating this equipment.
- Do not place hands or feet in any of the openings while equipment is running.
- Do not push or force material into the distributor.
- Do not overload distributor or use it for anything other than its intended use.
- Inspect all parts. Ensure parts are in good condition and installed properly.

2.4. LOCKOUT AND TAGOUT PROCEDURES

To minimize possibility of serious injury or death to workers from hazardous energy release (for example, when restarting the equipment) and prevent worker deaths from all forms of hazardous energy release (restarting of equipment), we recommend that you follow all lockout and tagout procedures when installing and servicing equipment. Ensure that all OSHA procedures are adhered to, for example:

- De-energize, block, and dissipate all sources of hazardous energy.
- Lock out and/or tag out all forms of hazardous energy.
- Ensure that only 1 key exists for each assigned lock, and that you are the only one that holds that key.
- After verifying all energy sources are de-energized, service or installation may be performed.
- Ensure that all personnel are clear before turning on power to equipment.

For more information on occupational safety practices, see www.osha.gov.

2.5. SAFETY DECAL LOCATIONS

- Keep safety decals clean and legible at all times.
- Replace safety decals that are missing or have become illegible.
- Replaced parts must display the same decal(s) as the original part.
- Safety decals are available from your distributor, dealer, or factory.

2.5.1. DECAL INSTALLATION

1. Installation area must be clean and dry, with a temperature above 10°C (50°F).
2. Decide on the exact position before you remove the backing paper.
3. Align the decal over the specified area and carefully press the small portion with the exposed sticky backing in place.
4. Slowly peel back the remaining paper and carefully smooth the remaining portion of the decal in place.
5. Small air pockets can be pierced with a pin and smoothed out using the piece of sign backing paper.

2.5.2. DECAL LOCATIONS

The types of safety decals and locations on the equipment are shown below. Good safety requires that you familiarize yourself with the various safety decals, the type of warning, and the area or particular function related to that area that requires your **SAFETY AWARENESS**.



PLACE GENERAL
WARNING (P200-
0017) AND CE
DECAL (P200-0020)
IN A CONVENIENT
LOCATION ON THE
EQUIPMENT.

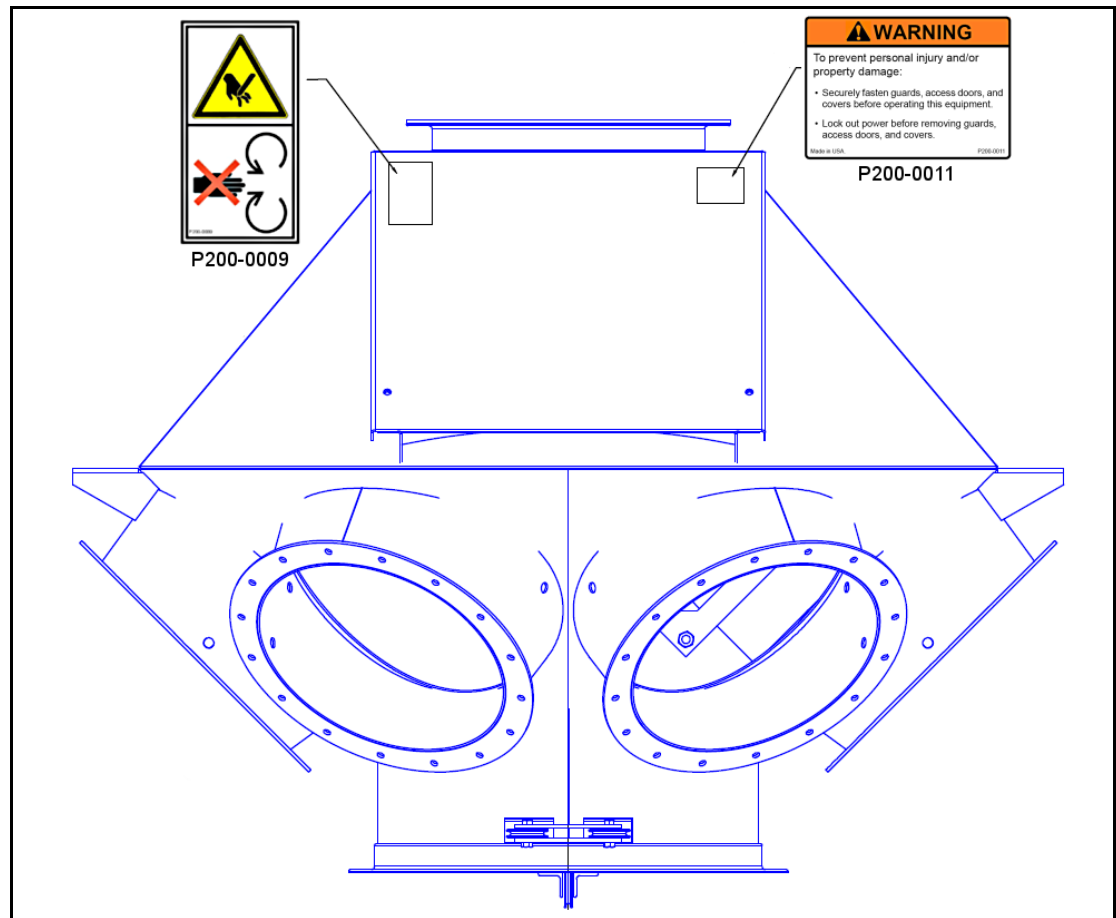

3. Assembly

WARNING

Before continuing, please reread the safety information relevant to this section at the beginning of this manual. Failure to follow the safety instructions can result in serious injury, death, or property damage.

See Figure 3.1 and 3.2.

1. Ensure all parts are present and in good condition before beginning assembly. The size of the distributor received will determine how many sections will need to be assembled.
2. If unit is to rest on a sub-structure, position anchor pads of the lower housing.
3. Insert bolts, nuts, and washers, but do not tighten; this will eliminate undue stress and will ease assembly.
4. Continue to assemble all remaining components according to the matching marks on the assembly drawing if the distributor has been shipped in sections.
5. After components are in place, tighten all bolts.
6. Tighten anchor pads to sub-structure.

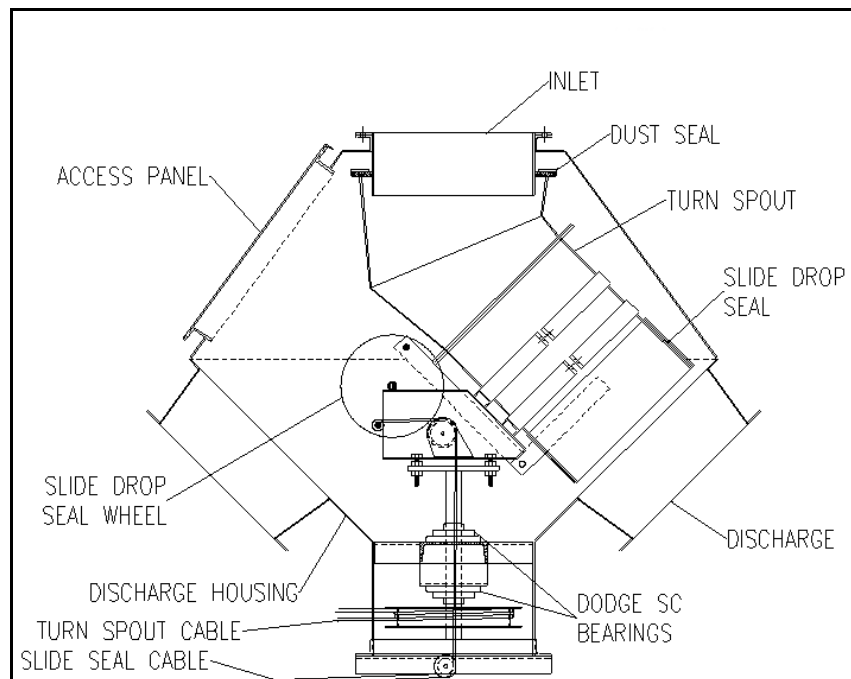

Figure 3.1 Manual Single Distributor

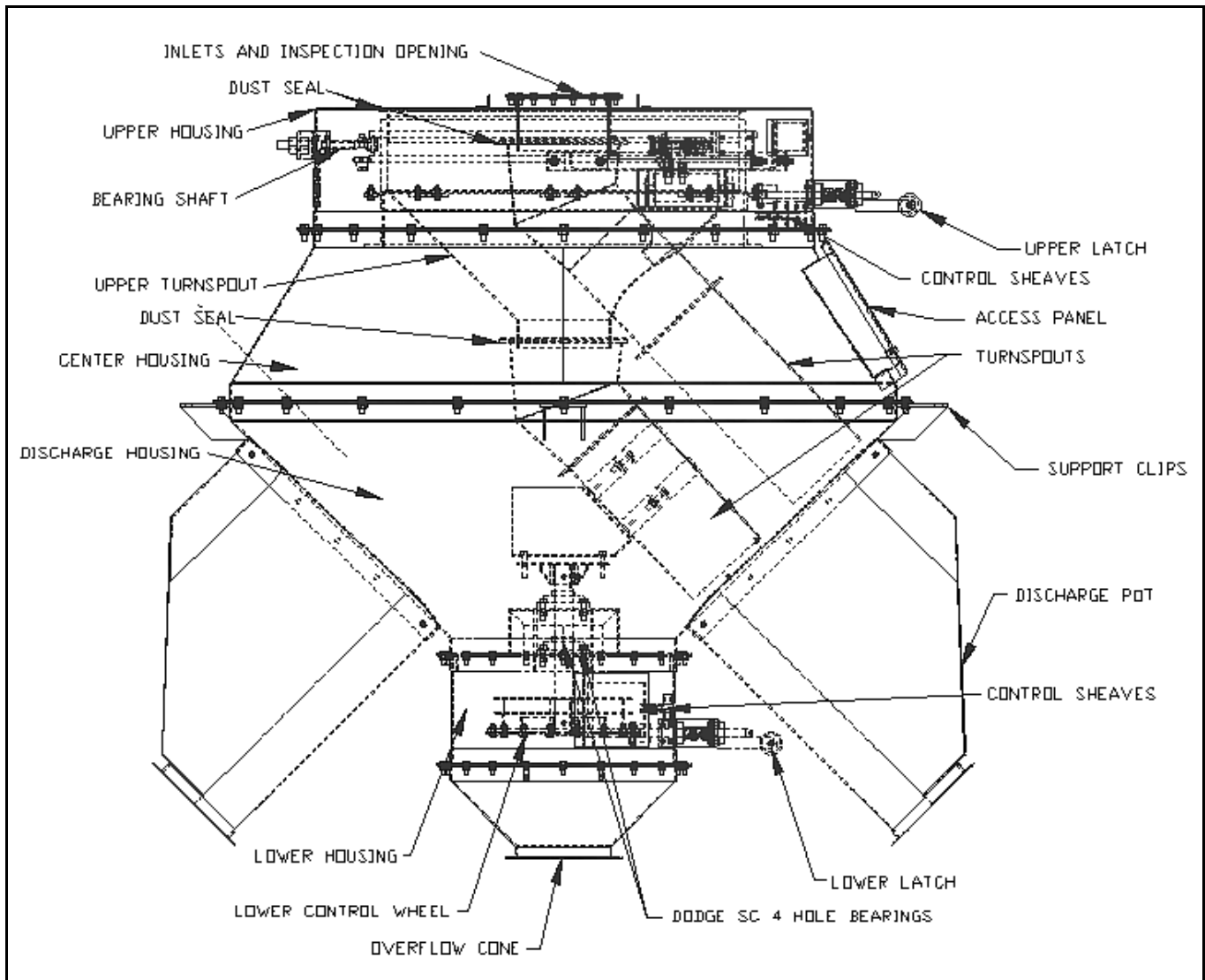

Figure 3.2 Manual Double Distributor

4. Operation

WARNING

Before continuing, please reread the safety information relevant to this section at the beginning of this manual. Failure to follow the safety instructions can result in serious injury, death, or property damage.

The Manual Distributor is very simple and straightforward to operate:

1. Depress slide drop seal lever to rotate selector wheel to desired position for the revolving spout. The spout will be located where the indicator on the wheel is pointing at.
2. When the spout reaches the desired location, release the slide drop seal lever and turn selector wheel to ensure seating of the slide drop seal.

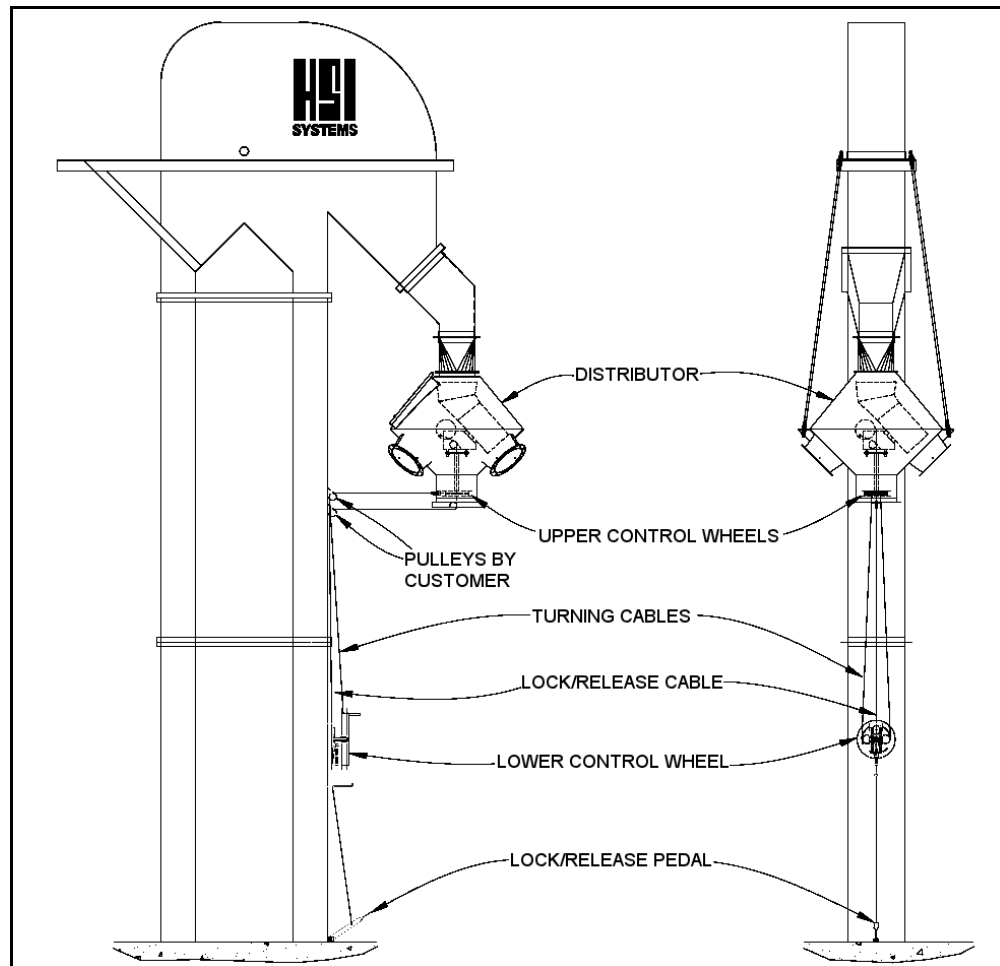

Figure 4.1

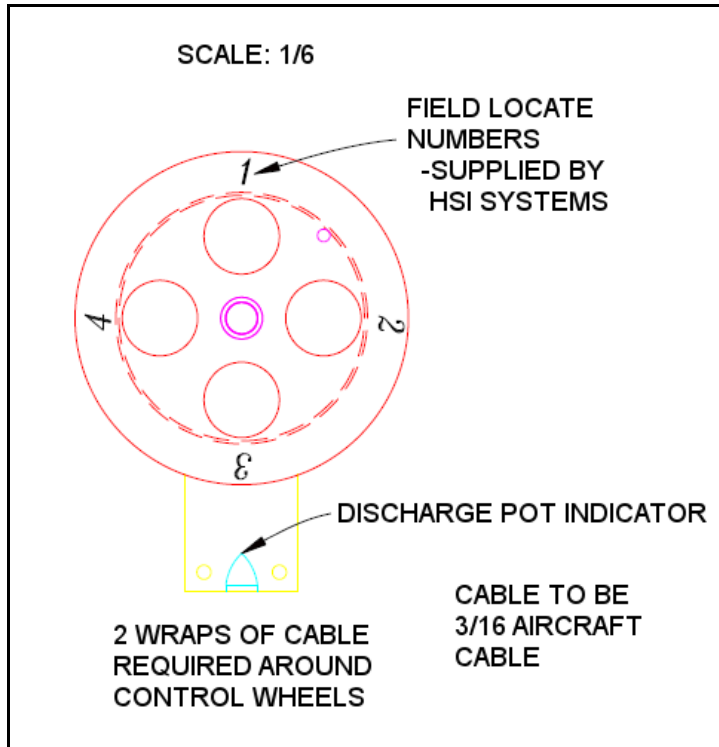

Figure 4.2

5. Maintenance

WARNING

Before continuing, please reread the safety information relevant to this section at the beginning of this manual. Failure to follow the safety instructions can result in serious injury, death, or property damage.

Regular maintenance is instrumental in reducing downtime and equipment failure. Operators and maintenance personnel should read and understand the instructions in this section. Proper maintenance will ensure many years of safe and economical, trouble-free operation.

CAUTION



Before performing any internal inspections or maintenance on the distributor, ensure that a mechanical lockout is in place on the selector wheel.

During maintenance, it is necessary to remove various service and inspection doors. These **doors must all be reinstalled** before operating the distributor as a safety and house-cleaning precaution.

Important: *Cables should be inspected every six months.*

5.1. BEARING AND SUPPORT SHAFT

The size of bearing and support shaft depends on the size of the internal spout, the number of outlets, and the diameter of the distributor.

One of the following size bearings will be used depending on the size of the distributor.

- 1-7/16" diameter Dodge SC (or equivalent) flange bearing
- 2" diameter Dodge SC (or equivalent) flange bearing

6. Troubleshooting

Table 6.1

Problem	Cause	Corrective Action
Selector wheel is turning but drive is not engaging.	• cable stretched	• readjust cable
	• cable broken	• repair cable
Bearings are making an unusual noise.	• bearings are improperly lubricated	• lubricate properly according to instructions in the manufacturer's service manual
	• bad bearing	• repair or replace
Slide drop seal lever not depressing or releasing.	• cable binding	• check for foreign matter
	• obstruction under pedal	• remove obstruction
Discharge spouts misalign with discharge pods.	• selector wheel misaligned	• realign and tighten

LIMITED WARRANTY

Seller warrants that all of the goods sold hereunder will conform to their description in Seller's published literature current at the time the Buyer's order is accepted, that Seller will use good material and workmanship in the manufacture of such goods, and that such goods will conform to applicable laws and regulations regarding purity.

Seller will repair or replace, at its discretion, any nonconforming goods (or refund their purchase price at Seller's option), but only if Seller receives written notice of nonconformity within 60 days after shipment and Buyer's remedies hereunder are expressly so limited.

Seller makes no other warranties of any kind with respect to such goods or any part thereof, express or implied. All implied warranties of merchantability and fitness for a particular purpose are hereby disclaimed by seller and excluded from this agreement, and such goods are sold "as is" and with all faults.

Seller will have no liability for consequential damages of any kind, including damages arising from bodily injury or the loss of use of such goods or other property. Buyer releases all claims for such damages, whether based on contract, warranties, strict liability, or negligence.



Huss & Schlieper Inc.

602 S. 27th Street

P.O. Box 1038

Decatur, IL 62525 USA

Phone: (217) 429-5148

Fax: (217) 429-5149

website: www.hsisystems.com